

Professionele meststofstrooier Hermie 25 liter  
Épandeur engrais professionnel Hermie 25 litres  
Professional fertilizer spreader Hermie 25 liter

**ASSEMBLY AND OPERATING INSTRUCTION MANUAL**



## SPECIFICATION

Capacity: 60LB  
Dimension of Hopper: 600x295x230mm  
Length of Handle: 870mm  
Net Weight: 3.3kgs  
Wheel Diameter: 12" (300mm)  
Poly Wheel













## IMPORTANT INSTRUCTIONS

### 1. HELPFUL HINTS:

READ THE DIRECTIONS BEFORE ASSEMBLY  
WHEN ALL ELSE FAILS, READ THE DIRECTIONS AGAIN

Your spreader is designed to be pushed at three miles per hour, which is a brisk walking speed. Slower or faster speeds will change the spread patterns. Wet fertilizer will also change the spread pattern and flow rate. Clean your spreader thoroughly after each use. Wash between the shut off plate and bottom of the hopper.

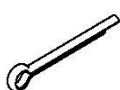
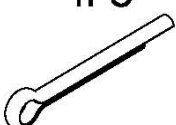
### 2. Remove and identify loose parts from carton and bag.

Hex Bolt M6x30 4PCS 	Hex Bolt M6x35 4PCS 	Screw M5x10 2PCS 	Carriage Bolt M6x35 2PCS 	Lock Nut M5 2PCS 	Lock Nut M6 2PCS 	Wire Crip Bottom Plate 1PC 
Wing Nut M6 8PCS 	Flat Washer Ø12 3PCS 	Big Flat Washer Ø6 4PCS 	Cotter Pin Ø3x30 1PC 	Cotter Pin Ø5x45 1PC 	Wire Crip Plate 1PC 	

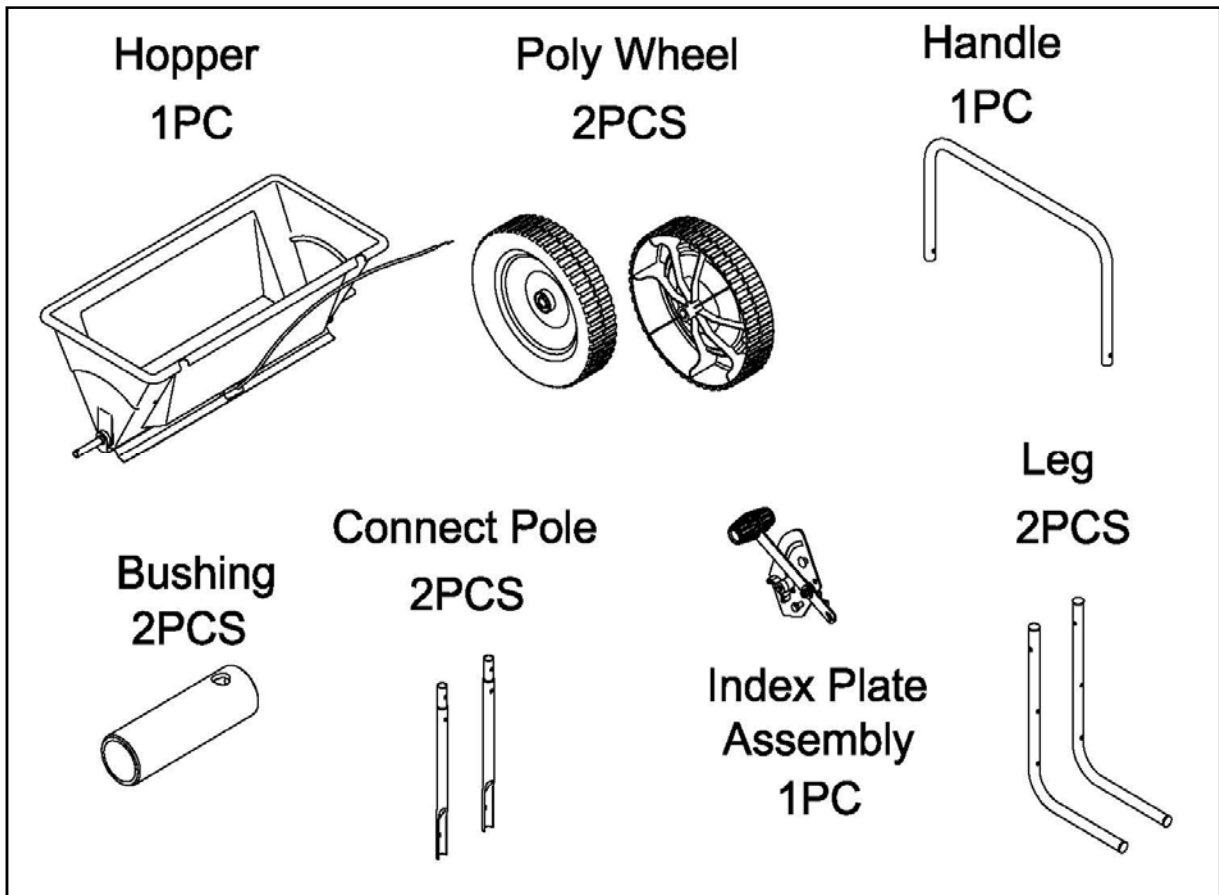

### 3. ASSEMBLY INSTRUCTIONS

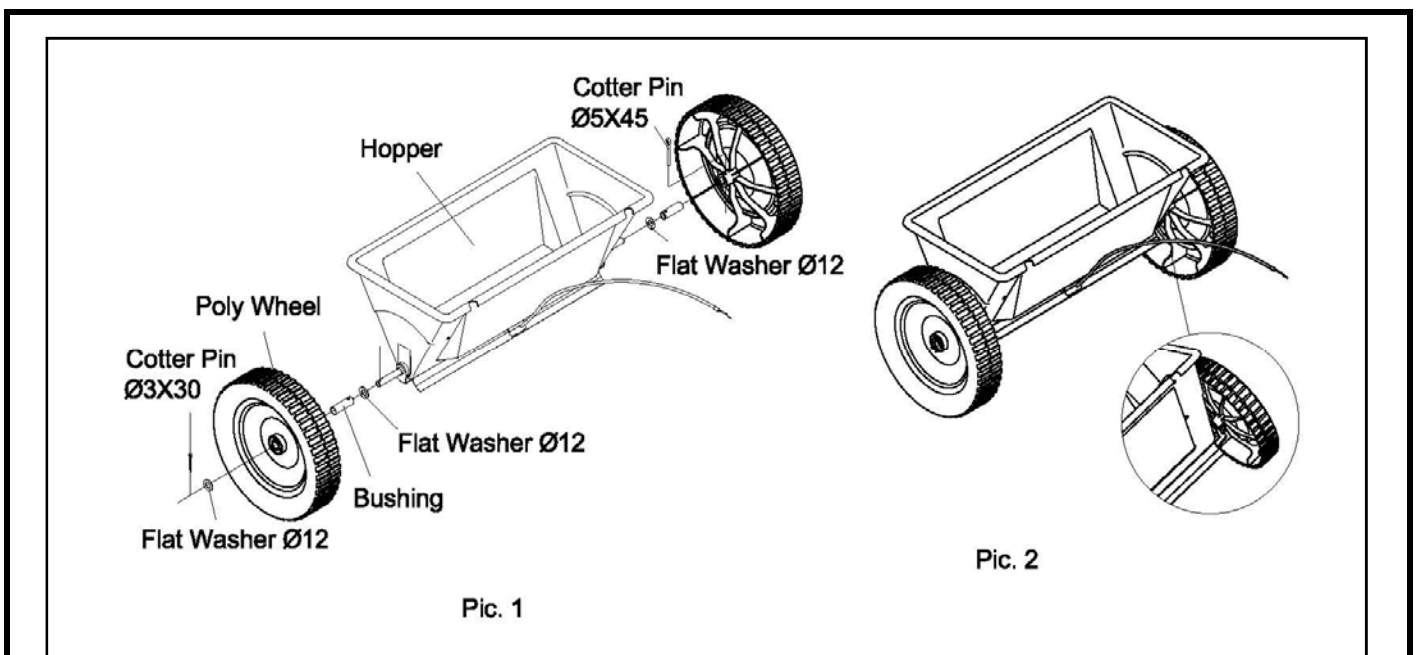

#### Assembly Step

1. As per Pic. 1, assemble a Flat Washer Ø12, a Bushing, a Poly Wheel on one end of the wheel axle, which has a Ø3 hole. Then go on assembling a Flat Washer Ø12, at this moment, please insert a Cotter Pin Ø3X30 into the Ø3 hole on the wheel axle and make the cotter bent for locking.
2. Assemble a Flat Washer Ø12, a Bushing, a Poly Wheel at the other end of the wheel axle. Turn the wheel till the Ø5 hole on the wheel is in the same line with the Ø5 hole on the wheel axle, insert the Cotter Pin Ø5X45 and make it bent for locking.

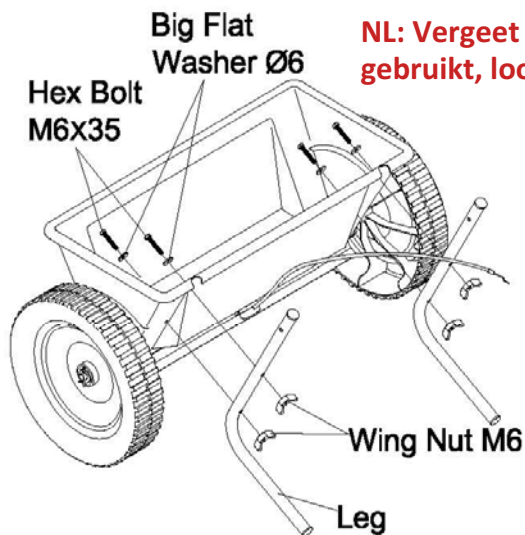

Pic. 3

**NL: Vergeet de sluitringen niet te gebruiken. Als je ze niet gebruikt, loop je het risico het plastic van het reservoir te scheuren.**

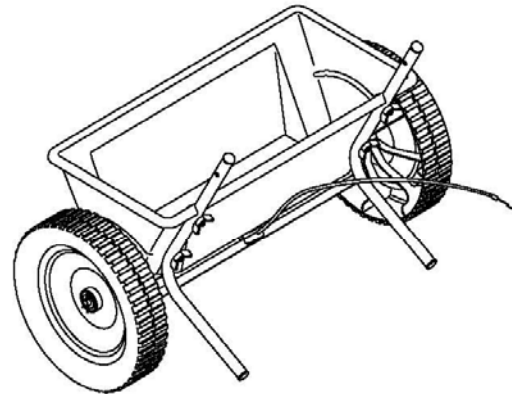

Pic. 4

**FR: N'oubliez pas les rondelles. Si vous ne les utilisez pas, vous risquez de déchirer le plastique du réservoir.**

### Assembly Step

1. As per Pic. 3, insert two Hex Bolt M6X35 with Big Flat Washer Ø6 from the inner hopper and a leg, then locked by two Wing Nut M6. Tighten the nuts.
2. Using the same way to assemble the other leg. See Pic.4.

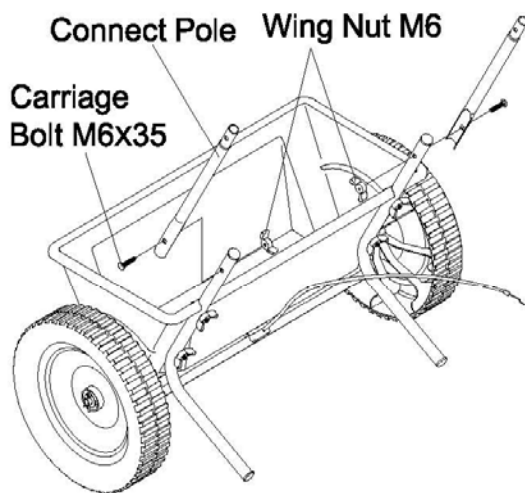

Pic. 5

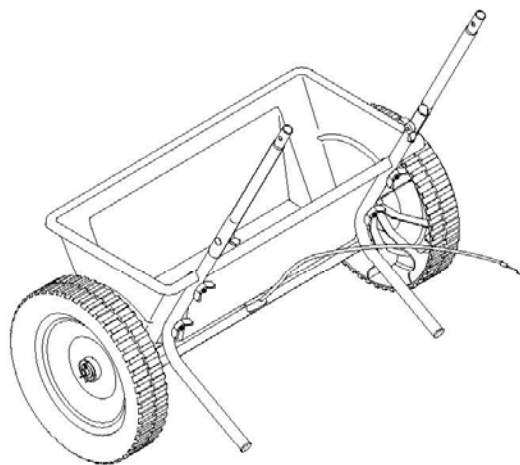

Pic. 6

### Assembly Step

1. As per Pic.5, assemble a Connect Pole onto the top of leg and locked by a Carriage Bolt M6X35 and a Wing Nut M6.
2. Use the same way to assemble the other Connect Pole. See Pic. 6.

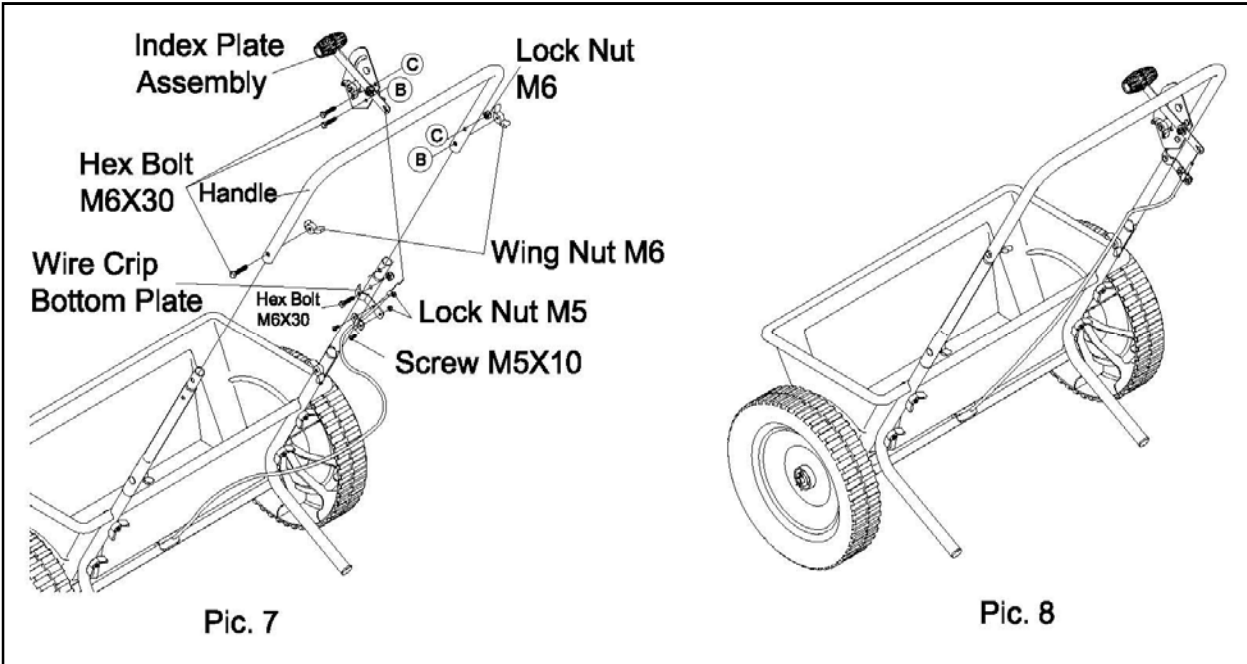

**Assembly Step**

1. As per Pic.7, connect the Handle with Connect Pole, locked by a Hex Bolt M6X30 and a Wing Nut M6 on the left.
2. On the right, insert the Adjustable Wire into the hole of Index plate, then assemble the Index plate on the handle and Connect Pole by using Hex Bolt M6x30, Lock Nut M6 and Wing Nut M6.
3. Assemble Wire Crip Bottom Plate on the Connect Pole by using Hex bolt M6x30 and Lock Nut M6
4. Use the Wire Crip Plate press the Adjustable Wire and Wire Crip Bottom Plate by using Screw M5x10 and Lock Nut M5. See pic. 8.

**ADJUSTING METHOD**

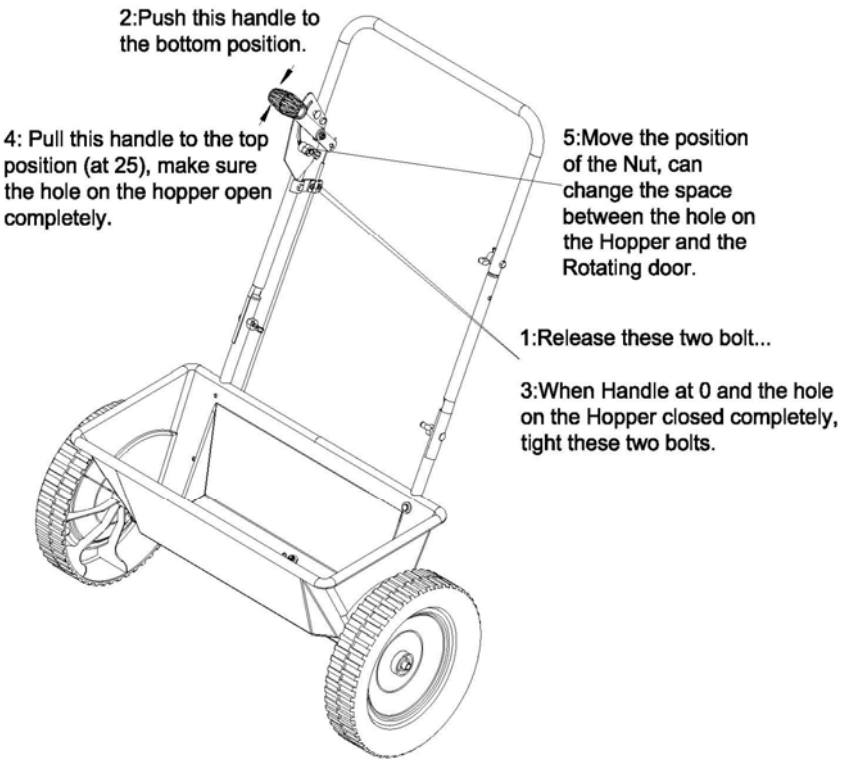

# SUGGESTED WALKING PATTERN

## FULL RATE SETTINGS

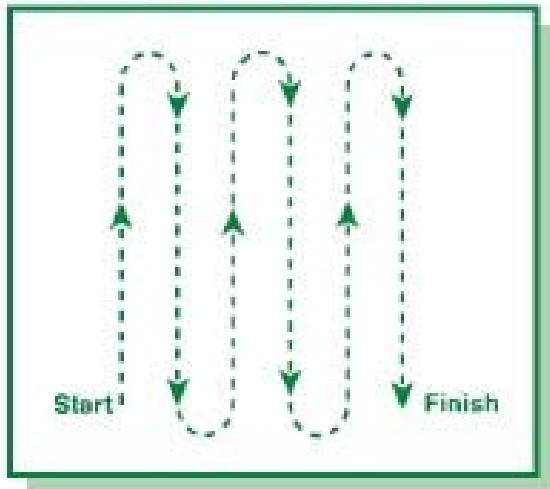

## HALF RATE SETTINGS

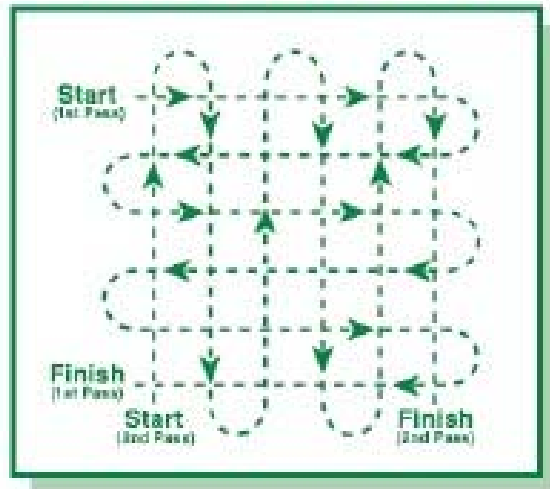

# PARTS DRAWING

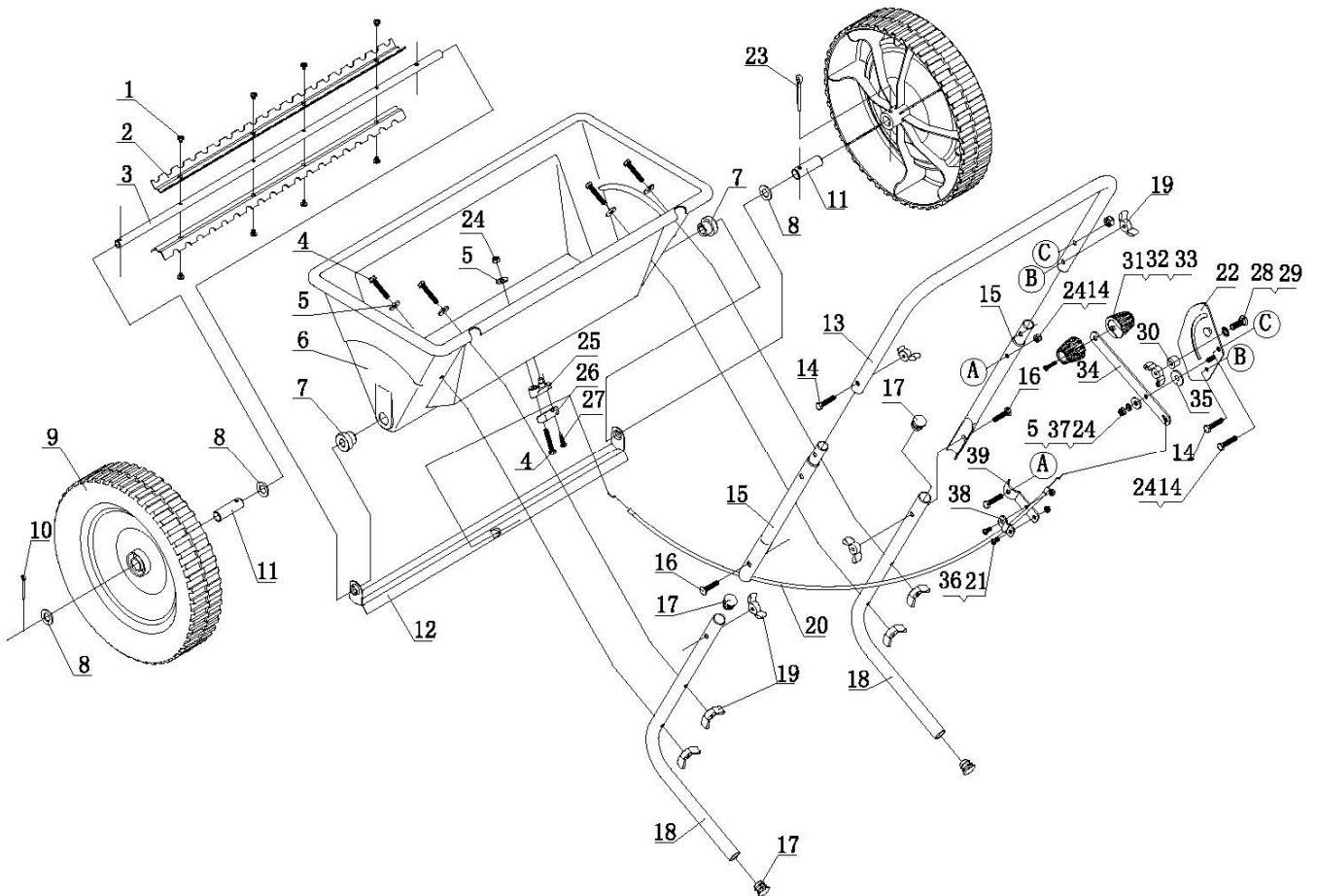

# PARTS LIST

Ref#	Description	Qty	Ref#	Description	Qty
1	Screw M5x6	8	21	Screw M5X10	2
2	Scratch Board	2	22	Index Plate Assembly	1
3	Wheel Axle	1	23	Cotter Pin Ø5X45	1
4	Hex Bolt M6X35	5	24	Nylon Lock Nut M6	4
5	Big Flat Washer Ø6	6	25	Wire Lock -1	1
6	Hopper	1	26	Wire Lock -2	1
7	Axle Bushing	2	27	Screw ST.4.8x20	1
8	Flat Washer Ø12	3	28	Carriage Bolt M6X25	1
9	Poly Wheel	2	29	Outer Teeth Washer Ø8	1
10	Cotter Pin Ø3X30	1	30	Spacer	1
11	Bushing	2	31	Adjustable Handle A	1
12	Rotating Door Assembly	1	32	Adjustable Handle B	1
13	Handle	1	33	Screw ST.4.2x18	1
14	Hex Bolt M6X30	4	34	Adjustable Handle Rod	1
15	Connect Pole	2	35	Nylon Washer	1
16	Carriage Bolt M6X35	2	36	Nylon Lock Nut M5	2
17	End Cap	4	37	Lock Washer Ø6	1
18	Support Leg	2	38	Wire Crip plate	1
19	Wing Nut	9	39	Wire Crip Bottom Plate	1
20	Adjustable Wire	1			